

# ELEVAH<sup>®</sup> 5

elevah.com



+  
**COMPACT  
COMPATTA**

+  
**WIDE  
SPAZIOSA**

+  
**HANDY  
MANEGGEVOLE**

+  
**COMFORTABLE  
CONFORTEVOLE**

+  
**SAFE  
SICURA**





## + COMPACT COMPATTA

The most compact of its category  
(footprint cm 70 x 98).  
La più compatta della sua  
categoria (ingombro base  
70x98 cm)



## + HANDY MANEGGEVOLE

It turns on itself.  
Extremely easy to drive.  
Ruota su sè stessa.  
Estremamente facile da guidare.





TECHNICAL  
DETAILS  
DETTAGLI  
TECNICI



## + COMFORTABLE COMFORTEVOLE

Practical and safe access thanks to the large platform and side handles. Accesso pratico e sicuro grazie all'ampia pedana e alle maniglie laterali



## + WIDE SPAZIOSA

Large basket, convenient for all sizes. Ampio cestello, comodo per tutte le taglie

## **+** SAFE SICURA

- **CONTROL ACCESS**  
Automatic door block. Prevents accidental opening.
- **TILT DEVICE**  
Prevents lifting on sloping surfaces.
- **SIGNALS**  
3 presence detectors that can be integrated with the BLU SPOT accessory
- **JOYSTICK**  
All controls at hand.
- **SPEED CONTROL**  
Speed control adjustment.

### **OPTIONAL**

- **RADAR SYSTEM**  
3 anti-collision radar systems can be fitted on the machine
- **KEY ACCESS**  
Basket block at max. 1,95 m platform height.

- **CONTROL ACCESS**  
Blocco automatico dello sportello. Evita l'apertura accidentale.
- **INCLINOMETRO**  
Impedisce il sollevamento in spazi inclinati
- **SEGNALATORI**  
Ben 3 segnalatori di presenza che possono essere integrati con l'optional BLUE SPOT
- **JOYSTICK**  
Tutti i controlli a portata di una sola mano
- **SPEED CONTROL**  
Regolatore di velocità

### **OPTIONAL**

- **RADAR SYSTEM**  
3 sistemi radar anticollisione applicabili alla macchina
- **KEY ACCESS**  
Blocco della macchina h. max. 1,95 al piede. Questo accessorio consente l'utilizzo della macchina senza patentino.







## PICKING VERSION VERSIONE PICKING

Picking plate having 100 kg safe load capacity, foldable and electrically adjustable.  
Piano picking con 100 kg di portata a regolazione elettrica e richiudibile di serie.



**OPTIONAL**  
Belt with winder to block the goods during picking activities  
Cinta per legare pacchi al piano picking con arrotolatore



**OPTIONAL**  
Extension for picking platform  
Prolunga per piano picking



**Customizable colors on request**  
Colori personalizzabili su richiesta



## REMOVABLE PICKING PLATE PIANO ASPORTABILE

On demand a fixed picking plate instead of the electrical one, having 3 possible adjustments.

Possibilità di sostituire il piano elettrico con quello asportabile a 3 regolazioni.



**Faradone**.com



**ELEVAH**.com



# ELEVAN<sup>®</sup>5 picking

Altezza massima di lavoro	5,15 m
Portata massima	200 kg
Numero Persone	1
Utilizzo	Interno - Esterno
<b>A</b> Altezza macchina chiusa	1690 mm
<b>B</b> Altezza minima da terra*	289 mm
<b>C</b> Altezza massima da terra al piano calpestio	3150 mm
<b>D</b>	1540 mm
<b>E</b> Ingombro macchina	700 mm
<b>F</b>	1152 mm
<b>G</b> Dimensioni cestello	685 mm
<b>H</b>	600 mm
Peso macchina	640 kg
Dimensioni ruote motrici	Ø 186 x 60 mm
Dimensioni ruote girevoli	Ø 150 x 40 mm

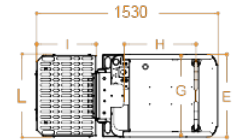
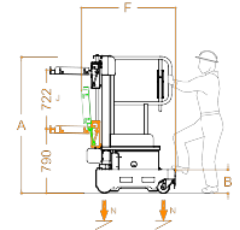

## PIANO PICKING

<b>I</b>	Dimensioni	500 mm
<b>L</b>		680 mm
Regolazione	Elettrico	
<b>J</b> Corsa	722 mm	
Altezza minima da terra	790 mm	
Altezza massima da terra	4102 mm	
Portata	100 kg	

## PRESTAZIONI

Alimentazione	Elettrica 24 V	
Batterie	2 Pb Acido Trojan 12V 105Ah	
Caricabatterie	115V - 230V 50/60HZ	
<b>M</b> Pendenza massima superabile	15%	
Pendenza massima superabile in quota	2,5%	
Raggio di sterzata interno	0	
Raggio di sterzata esterno	1050 mm	
Velocità massima (salita - discesa)	0,2 m/s	
Velocità massima con cestello a terra	5,5 km/h	
<b>N</b> Pressione massima per ruota a pieno carico**	2,9 kN	
Cicli di lavoro (con batterie cariche) ***	100	

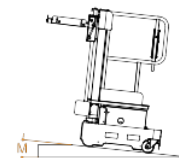
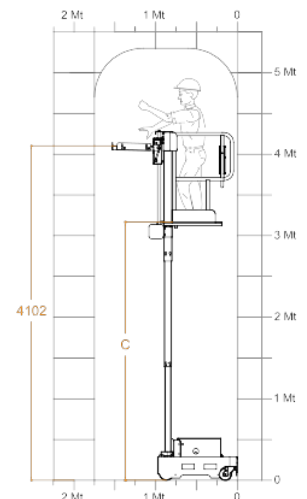

\* E' presente un gradino intermedio

\*\* Pressione massima considerando che il peso della piattaforma più il carico massimo a bordo del cestello siano completamente distribuiti su un solo lato della piattaforma (carico totalmente asimmetrico).

\*\*\* Per ciclo di lavoro si intende una semovenza di 20 m ed una salita e discesa completa alla massima altezza, con regolazione del piano di carico.

**CE** Conforme alle norme europee sui carrelli elevatori con uomo in alto. UNI EN ISO 3691-1.